



# AMAIRCARE Model AirWashPRO

## 115VAC Air Scrubbing Filtration System

### SPECIFICATIONS

#### CLASSIFICATION

- Portable HEPA (High Efficiency Particulate Arrestance) 100% Sealed Air Cleaning Device

**DIMENSIONS:** 19"W x 20"H x 32"L

**WEIGHT:** 42 lbs

**AIR FLOW (C.F.M.):** 690 CFM delivered (nominal)

**POWER USAGE:** 235 Watts, 2 AMPS

**HEPA MATERIAL:** 100 sq.ft.

**FINISH:** Rotomold Plastic, Meets CSA 22.2 No 0.6 flammability requirements for polymer cabinets housing energized electrical components

**COLOR(S):** Grey

**SERVICE AREA:** 5,175 sq ft (1 ACH per Hour)

**INTAKE:** 12" Round

**OUTFLOW:** 12" Round with safety screen

**SUPPLY:** 115 VAC/1 phase/60 HZ Grounded

**CONTROL:** OFF/ON Variable Speed with indicating lights for power ON and Filter Change

**PROTECTION:** Resistible thermal circuit breaker, thermally protected motor, accessory receptacle with ground fault, circuit Interrupter (12 AMP 115 VAC Accessory Load)

**CERTIFICATIONS:** This equipment meets the technical requirements of CSA C22.2 No. 0,0.4, CSA Model Code SPE 1000 and CE 2015

#### FILTER OPTIONS

- Aluminum mesh pre filter
- 5 lb Granulated Carbon Canister (replaces 4th stage inner carbon blanket) added odor absorption
- 25 lb Upgraded Carbon Canister (replaces 3rd stage HEPA cartridge) for extreme odor absorption

Amaircare AirWashPRO air scrubbing systems effectively provide filtration for abatement, industrial, healthcare and renovation applications.

### Three-Stage Filtration

#### Stage 1: Prefilter

Removes Large Dust Particles – Disposable.

#### Stage 2: Washable Foam Filter

Captures small and medium dust particles that pass through the first stage filter. Extends the life of the HEPA filter. (Note after some applications it is recommended that all the filters are disposed of rather than cleaned)

#### Stage 3: HEPA Filter

99.97% efficient @ 0.3 microns. Removes dust, pollen, bacteria, dander, attached viruses, cigarette smoke, radon daughters and more.

#### Stage 4: Inner Carbon V.O.C. Blanket

Removes gas molecules, including V.O.C.'s that could be hazardous.

### No Tools Needed

Filters can be accessed and changed without any tools required.

### Stackable

up to 3 units.

### Daisy-Chain Power Outlet

up to 5 units.

### Removable Filter Cabinet

makes for easy to change filters and easy cleaning between uses.

### 2 Carry Options

1 flexible handle at the top of the unit and 2 moulded handles on the side of the unit.

### Rubber Feet

minimize vibration.

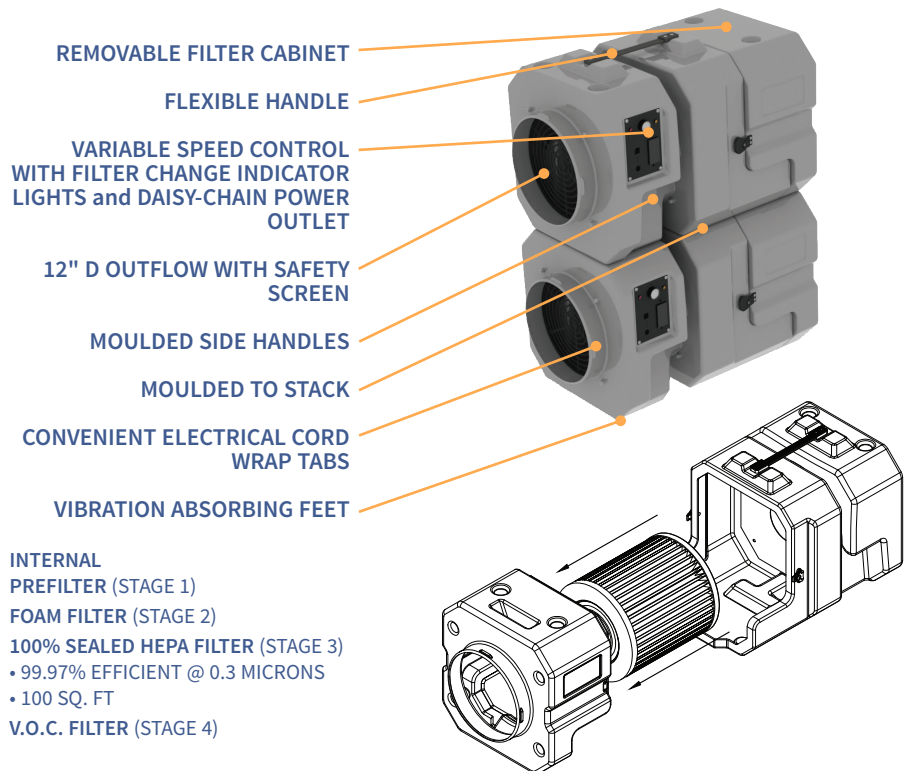

[www.amaircare.com](http://www.amaircare.com)

**amaircare**<sup>®</sup>  
Cleaning the air you breathe.

**airwash**<sup>®</sup>  
**PRO**

DESIGNED AND MANUFACTURED BY AMERICAIR CORPORATION, MISSISSAUGA, CANADA.

Amaircare<sup>®</sup> is a trade mark (registered in the U.S. and Canada) of Americair Corporation. Americair Corporation reserves the right to change any specifications without notice.